



4J31-4J35 inclusive

S-BAND MAGNETRONS

Service Types CV1914, CV1916, CV1897,
CV1898, CV2744

ABRIDGED DATA

Fixed frequency pulse magnetrons

Frequency range:

4J31 (CV1914)	2860 to 2900	MHz
4J32	2820 to 2860	MHz
4J33 (CV1916)	2780 to 2820	MHz
4J34 (CV1897)	2740 to 2780	MHz
CV2744 (selected 4J34)	2740 to 2765	MHz
4J35 (CV1898)	2700 to 2740	MHz

Typical peak output power

1.0 MW

Magnet

separate, see note 8 on page 5
coaxial line; internal diameter of
outer conductor 1.527 inches, diam-
eter of inner conductor 0.625 inch

Output

Coupler

see page 7

Cooling

forced-air

GENERAL

Electrical

Cathode		indirectly heated
Heater voltage (see note 1)	16	V
Heater current	3.1	A
Heater starting current, peak value, not to be exceeded	15	A max
Cathode heating time (minimum) (see note 2)	2	min

Mechanical

Overall dimensions	10.523 x 7.233 x 4.624 inches max 267.3 x 183.7 x 117.5mm max
Net weight	6 pounds (2.8kg) approx
Mounting position	any
Cooling (see note 6)	forced-air

MAXIMUM AND MINIMUM RATINGS (Absolute values)

These ratings cannot necessarily be used simultaneously, and no individual rating should be exceeded.

	Min	Max	
Heater voltage (see note 1)	14.4	17.6	V
Heater starting current (peak)	—	15	A
Anode voltage (peak)	—	30	kV
Anode current (peak)	—	70	A
Input power (peak)	—	2.0	MW
Input power (mean) (see note 3)	—	1.2	kW
Duty cycle	—	0.001	
Pulse length (see note 4)	—	2.5	μ s
Rate of rise of voltage pulse (see note 5)	100	200	kV/ μ s
Anode temperature (see note 6)	—	100	$^{\circ}$ C
Cathode terminal temperature	—	100	$^{\circ}$ C
V.S.W.R. at the output coupler	—	1.5:1	
Ambient pressure for satisfactory operation	500	—	mm Hg
Pressurising (see note 7):			
input circuit	—	45	lb/in ²
output circuit	—	45	lb/in ²

TYPICAL OPERATION

Operational Conditions

Heater voltage	13	10.5	V
Magnetic field (see note 8)	2150	2700	gauss
Anode current (peak)	56	70	A
Pulse length	1.0	1.0	μ s
Pulse repetition rate	500	500	p.p.s.

Typical Performance

Anode voltage (peak)	22	28	kV
Output power (peak)	600	1000	kW
Output power (mean)	300	500	W

TEST CONDITIONS AND LIMITS

The valve is tested to comply with the following electrical specification

Test Conditions

	Oscillation		
	1	2	
Magnetic field (see note 8)	2700	2700	gauss
Heater voltage (for test)	10	10	V
Anode current (mean)	35	45	mA
Duty cycle	0.0005	0.0006	
Pulse length (see note 4)	1.0	2.0	μ s
V.S.W.R. at the output coupler	1.15:1	1.15:1	
Rate of rise of voltage pulse (see note 5)	200	200	kV/ μ s

Limits

	Min	Max	Min	Max	
Anode voltage (peak)	26	30	—	—	kV
Output power (mean)	400	—	—	—	W
Frequency:					
4J31 (CV1914)	2860	2900	—	—	MHz
4J32	2820	2860	—	—	MHz
4J33 (CV1916)	2780	2820	—	—	MHz
4J34 (CV1897)	2740	2780	—	—	MHz
CV2744*	2740	2765	—	—	MHz
4J35 (CV1898)	2700	2740	—	—	MHz
R.F. bandwidth at $\frac{1}{4}$ power	—	2.5	—	—	MHz
Frequency pulling (v.s.w.r. not less than 1.5:1)	—	15	—	—	MHz
Stability (see note 9)	—	0.5	—	0.5	%
Heater current					see note 10
Temperature coefficient of frequency					see note 11

* Selected 4J34 with limited frequency band.

LIFE TEST

The quality of all production is monitored by the random selection of valves which are then life-tested under Oscillation 1 conditions above. If the valve is to be operated under conditions other than those specified herein, English Electric Valve Company Ltd. should be consulted to verify that the life of the valve will not be impaired.

End of Life Criteria (under Test Conditions Oscillation 1)

Output power (mean)	320	W min
R.F. bandwidth at ¼ power	2.5	MHz max
Stability (see note 9)	1.0	% max

NOTES

- (a) With no anode input power.
During high voltage operation it is essential to operate the heater according to the following schedule:

Mean Input Power (W)	Heater Voltage (V)
1000—1200	8.0
800—1000	10.5
600—800	13
400—600	15
less than 400	16

The above schedule is valid only for pulse repetition rates of 300p.p.s. or greater.

The valve heater shall be protected against arcing by the use of a minimum capacitance of 4000pF shunted across the heater directly at the input terminals; in some cases a capacitance as high as 2μF may be necessary depending on the equipment design. For further details see the preamble to this section.

- (b) The 4J31—4J35 types have hum-free heaters and have been tested for satisfactory operation with sinusoidal heater supply voltages of frequency 50, 60 and 500Hz. English Electric Valve Company Ltd. should be consulted if other supply frequencies are to be used. Where complete freedom from frequency modulation is essential, the use of a d.c. heater supply is recommended.
- For ambient temperatures above 0°C. For ambient temperatures between 0 and -55°C the cathode heating time is 3 minutes minimum.
- The various parameters are related by the following formula:
$$P_i = i_{apk} \times v_{apk} \times D_u$$
where P_i = mean input power in watts
 i_{apk} = peak anode current in amperes
 v_{apk} = peak anode voltage in volts
and D_u = duty cycle.

4. Tolerance $\pm 10\%$.
5. The rate of rise of voltage is the slope of the steepest tangent to the leading edge of the voltage pulse above 80% amplitude. Any capacitance used in the viewing system must not exceed 6.0pF.
6. The anode temperature must be kept below the limit specified by means of a suitable flow of air over the cooling fins.
7. The mounting plate and the guard pipe are fitted to the valve in a manner to permit pressurising of the input circuit and the output circuit of the valve. At the maximum pressure of 45lb/in² absolute, the leakage will not exceed 0.5 litre (N.T.P.) per minute.
8. The valve is designed for use with a separate magnet which must conform with the specification given at the top of page 11. The axis of the magnetic field must be coincident with the axis of the anode, and the north pole of the magnet must be adjacent to the cathode terminal. A suitable magnet, type MA228, is available.
If an electro-magnet is used, the pole tip dimensions should be as shown on page 11.
9. With the valve operating into a mismatch of v.s.w.r. 1.5:1, phased to give maximum instability. Pulses are defined as missing when the r.f. energy level is less than 70% of the normal energy level in the rated frequency range of the valve. Missing pulses are expressed as a percentage of the number of input pulses applied during the last 30 seconds of a test interval not to exceed 5 minutes.
10. Measured with heater voltage of 16V and no anode input power, the heater current limits are 2.8A minimum, 3.4A maximum.
11. Design test only. The maximum frequency change with anode temperature change (after warming) is $-0.07\text{MHz}/^{\circ}\text{C}$.

PERFORMANCE CHART

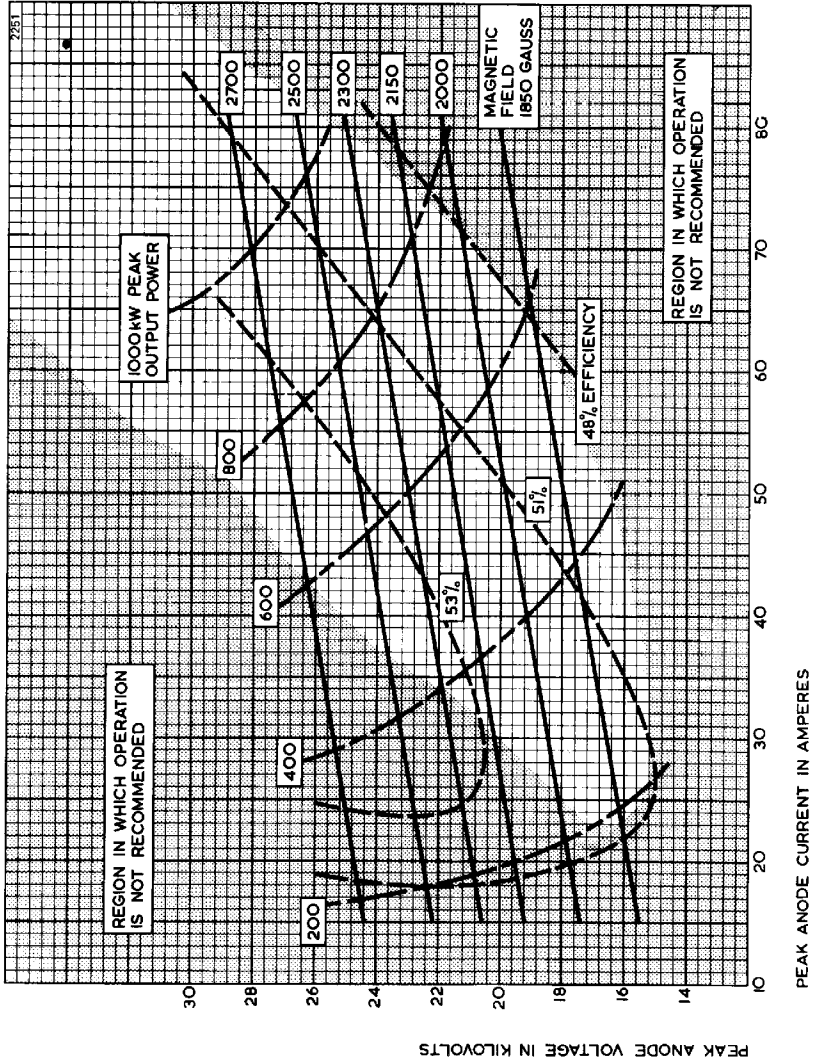

COUPLER

2252

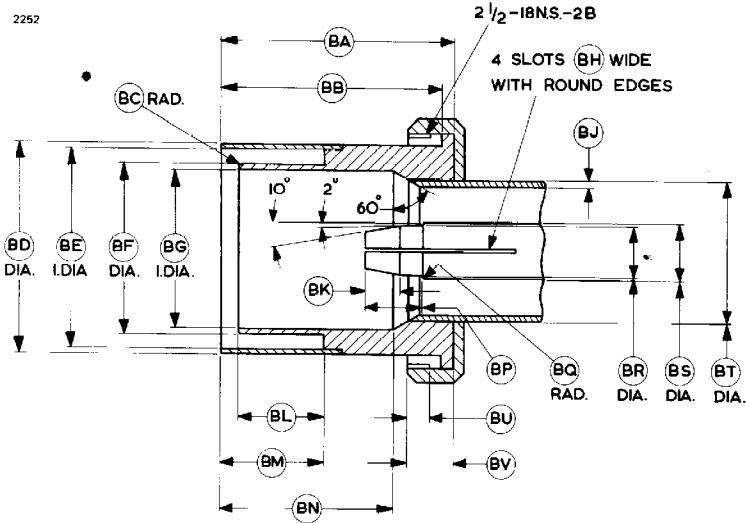

Ref	Inches	Millimetres	Ref	Inches	Millimetres
BA	2.531 ± 0.015	64.29 ± 0.38	BL	0.937 ± 0.003	23.800 ± 0.076
BB	2.402 ± 0.005	61.01 ± 0.13	BM	1.125 ± 0.003	28.575 ± 0.076
BC	0.031 ± 0.015	0.79 ± 0.38	BN	1.875 ± 0.005	47.63 ± 0.13
BD	2.310 ± 0.002	58.674 ± 0.051	BP	0.625 ± 0.015	15.88 ± 0.38
BE	2.185 ± 0.002	55.499 ± 0.051	BQ	0.016 ± 0.015	0.41 ± 0.38
BF	1.875 ± 0.002	47.625 ± 0.051	BR	0.576 ± 0.002	14.630 ± 0.051
BG	1.720 ± 0.002	43.688 ± 0.051	BS	0.625	15.88
BH	0.030	0.76	BT	1.625	41.28
BJ	0.049	1.24	BU	0.250 ± 0.015	6.35 ± 0.38
BK	0.375 ± 0.015	9.53 ± 0.38	BV	0.500 ± 0.015	12.70 ± 0.38

Millimetre dimensions have been derived from inches.

OUTLINE (See page 10 for outline notes)

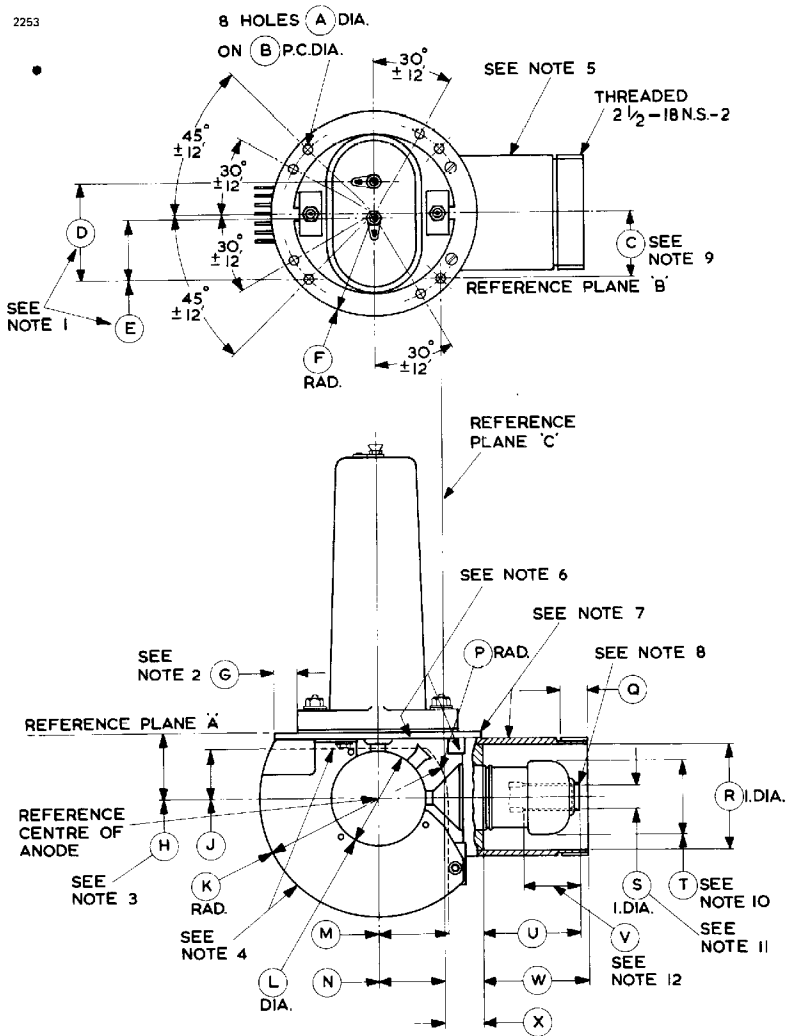

OUTLINE DIMENSIONS

Ref	Inches	Millimetres	Ref	Inches	Millimetres
A	0.210 ± 0.005	5.33 ± 0.13	Q	0.593 min	15.06 min
B	2.032 ± 0.003	51.613 ± 0.076	R	2.321 ± 0.007	58.95 ± 0.18
C	1.437 ± 0.020	36.50 ± 0.51	S	0.555 ± 0.005	14.10 ± 0.13
D	2.156	54.76	T	1.620 max	41.15 max
E	1.359	34.52	U	2.085 ± 0.025	52.96 ± 0.64
Γ	2.281 ± 0.031	57.94 ± 0.79	V	1.125 min	28.58 min
G	0.500 min	12.70 min	W	2.297 ± 0.010	58.34 ± 0.25
H	1.440	36.58	X	0.818 ± 0.015	20.78 ± 0.38
J	1.063 min	27.00 min	AA	6.313 ± 0.094	160.35 ± 2.39
K	2.656 max	67.46 max	AB	1.440 ± 0.020	36.58 ± 0.51
L	2.062	52.37	AC	0.187	4.75
M	1.500 min	38.10 min	AD	0.677 min	17.20 min
N	1.437	36.50	AE	1.490 max	37.85 max
P	1.500 min	38.10 min	AF	2.197 max	55.80 max

Millimetre dimensions have been derived from inches.

OUTLINE

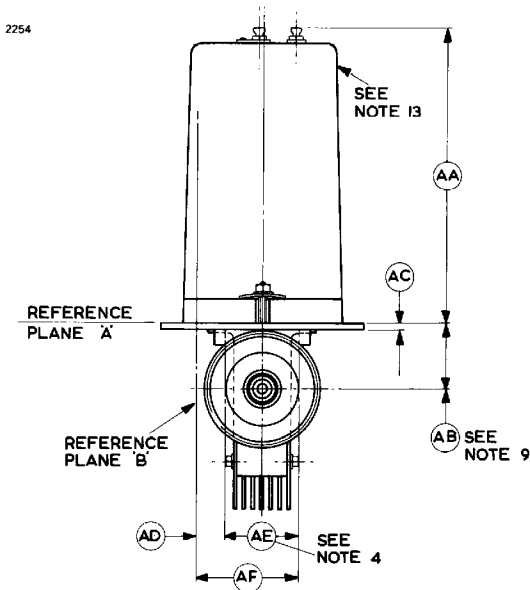

OUTLINE NOTES

1. The centres of the jack holes will be within a radius of 0.100 inch (2.54mm) of the location specified, but spaced 0.797 ± 0.015 inch (20.24 ± 0.38 mm) with respect to each other.
2. With the valve resting on a plane surface, the flatness of this annular area will be such that a feeler gauge 0.015 inch (0.38mm) thick and 0.125 inch (3.18mm) wide will not enter more than 0.250 inch (6.35mm) at any point.
3. The periphery of the anode will lie within a 2.160 inch (54.86mm) diameter circle located as specified.
4. The maximum width specified by dimension 'AE' applies to the area defined by the broken line and the circumference of the radiator.
5. The valve will be painted with black, heat resisting, non-corrosive paint, except for the following paint free areas: top surface of mounting plate, parts above mounting plate, screw threads on guard pipe and all surfaces inside the guard pipe.
6. All joints on the mounting plate and guard pipe will be soldered to provide hermetic seals.
7. The valve may be supported by the mounting plate or guard pipe.
8. There will be no sharp edges on the outside diameter at the end of the inner conductor.
9. Applies to the location of the centre line of the guard pipe.
10. The centre line of the glass portion will be concentric with the centre line of the guard pipe to within 0.040 inch (1.02mm).
11. Applies to the inner conductor insert only. The centre line of the inner conductor insert will be concentric with the centre line of the guard pipe to within 0.025 inch (0.64mm).
12. Applies to the straight portion of the inner conductor wall.
13. The common cathode connection is indicated by letter C.

PERMANENT MAGNET SPECIFICATION

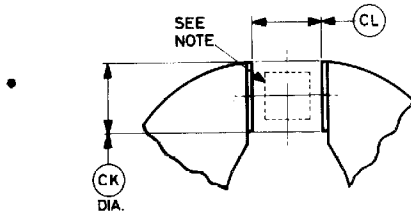

Ref	Inches	Millimetres
CK	1.500	38.10
CL	1.500 ^{+ 0.010} - 0.000	38.10 ^{+ 0.25} - 0.00

Millimetre dimensions have been derived from inches.

Note The variation of magnetic field within a cylinder 1.000 inch (25.4mm) long and 0.900 inch (22.86mm) diameter situated centrally and coaxially between the poles must not exceed ± 140 gauss.

ELECTRO-MAGNET POLE PIECES

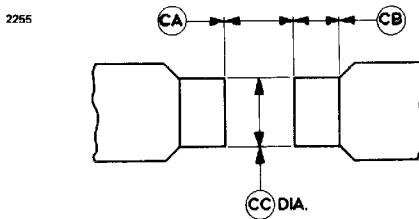

Ref	Inches	Millimetres
CA	1.500 ^{+ 0.005} - 0.000	38.10 ^{+ 0.13} - 0.00
CB	1.000 min	25.40 min
CC	1.500 \pm 0.010	38.10 \pm 0.25

Millimetre dimensions have been derived from inches.